



UNIVERSITY OF CAMBRIDGE INTERNATIONAL EXAMINATIONS
 General Certificate of Education
 Advanced Subsidiary Level and Advanced Level

CANDIDATE
NAME

CENTRE
NUMBER

| | | | | |
|--|--|--|--|--|
| | | | | |
|--|--|--|--|--|

CANDIDATE
NUMBER

| | | | |
|--|--|--|--|
| | | | |
|--|--|--|--|

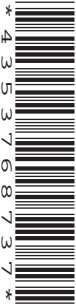

MARINE SCIENCE

9693/03

Structured Questions

October/November 2012

Paper 3

1 hour 30 minutes

Candidates answer on the question paper.

No Additional Materials are required.

READ THESE INSTRUCTIONS FIRST

Write your Centre number, candidate number and name on all the work you hand in.

Write in dark blue or black pen on both sides of the paper.

You may use a soft pencil for any diagrams, graphs or rough working.

Do not use staples, paper clips, highlighters, glue or correction fluid.

DO NOT WRITE IN ANY BARCODES.

Answer **all** questions.

Write your answers in the spaces provided on the question paper.

At the end of the examination, fasten all your work securely together.

The number of marks is given in brackets [] at the end of each question or part question.

| For Examiner's Use | |
|--------------------|--|
| 1 | |
| 2 | |
| 3 | |
| 4 | |
| 5 | |
| 6 | |
| 7 | |
| Total | |

This document consists of **14** printed pages and **2** blank pages.



1 (a) State what is meant by the term *thermocline*.

.....

.....

..... [2]

(b) Fig. 1.1 shows the vertical distribution of water temperature and density in sea water.

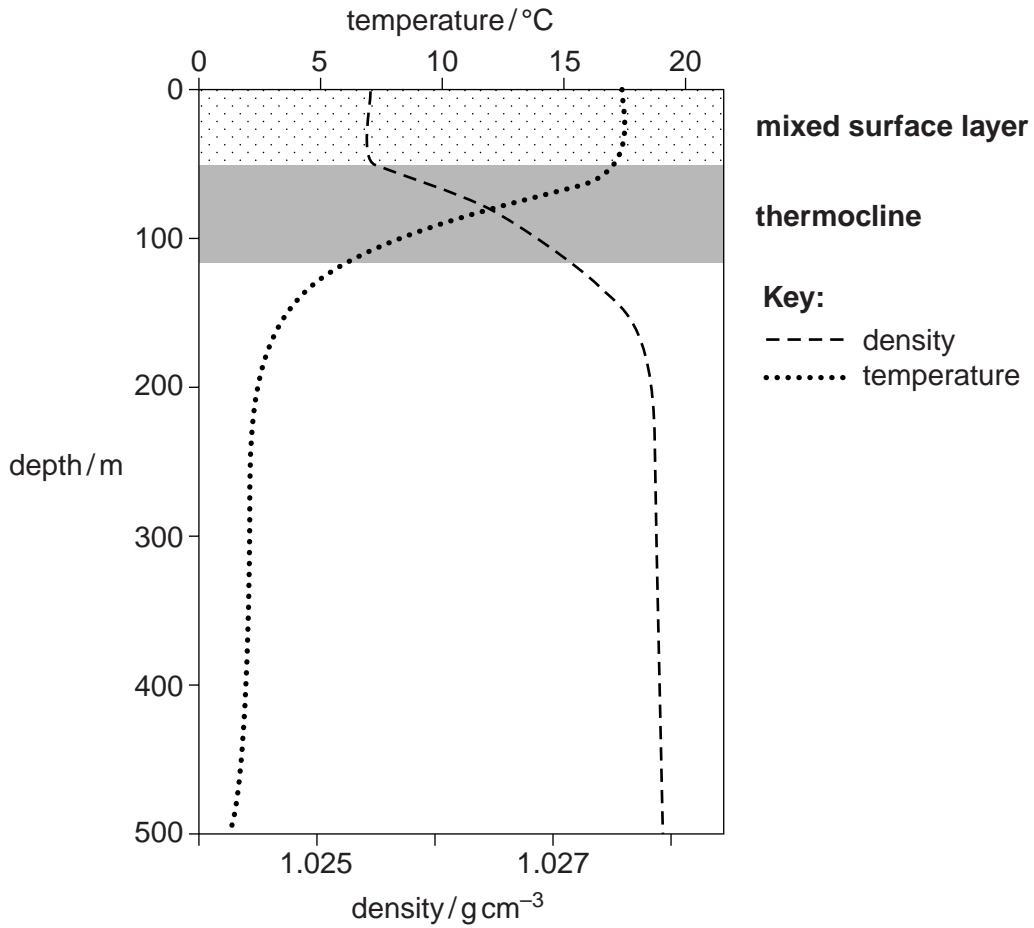

Fig. 1.1

(i) Seas close to the equator have a surface temperature between 20 – 24°C.

Use the information in Fig. 1.1 to explain why a permanent thermocline develops in these seas.

.....

.....

.....

.....

.....

.....

..... [3]

(ii) Explain why the presence of a permanent thermocline decreases the productivity of these seas.

*For
Examiner's
Use*

.....
.....
.....
..... [2]

(c) Explain why the majority of the organisms living in the sea are found in the surface layer.

.....
.....
.....
.....
.....
.....
..... [3]

[Total: 10]

2 (a) (i) What is meant by the term *euryhaline*?

.....
..... [1]

(ii) With reference to their life cycle, explain why salmon are described as euryhaline fish.

.....
.....
.....
..... [3]

(b) An estuary is formed where a river flows into the sea. The sea flows into and out of the river when the tide flows and ebbs.

Fig. 2.1 shows the results of a survey into the number of different mollusc species found at different distances along an estuary.

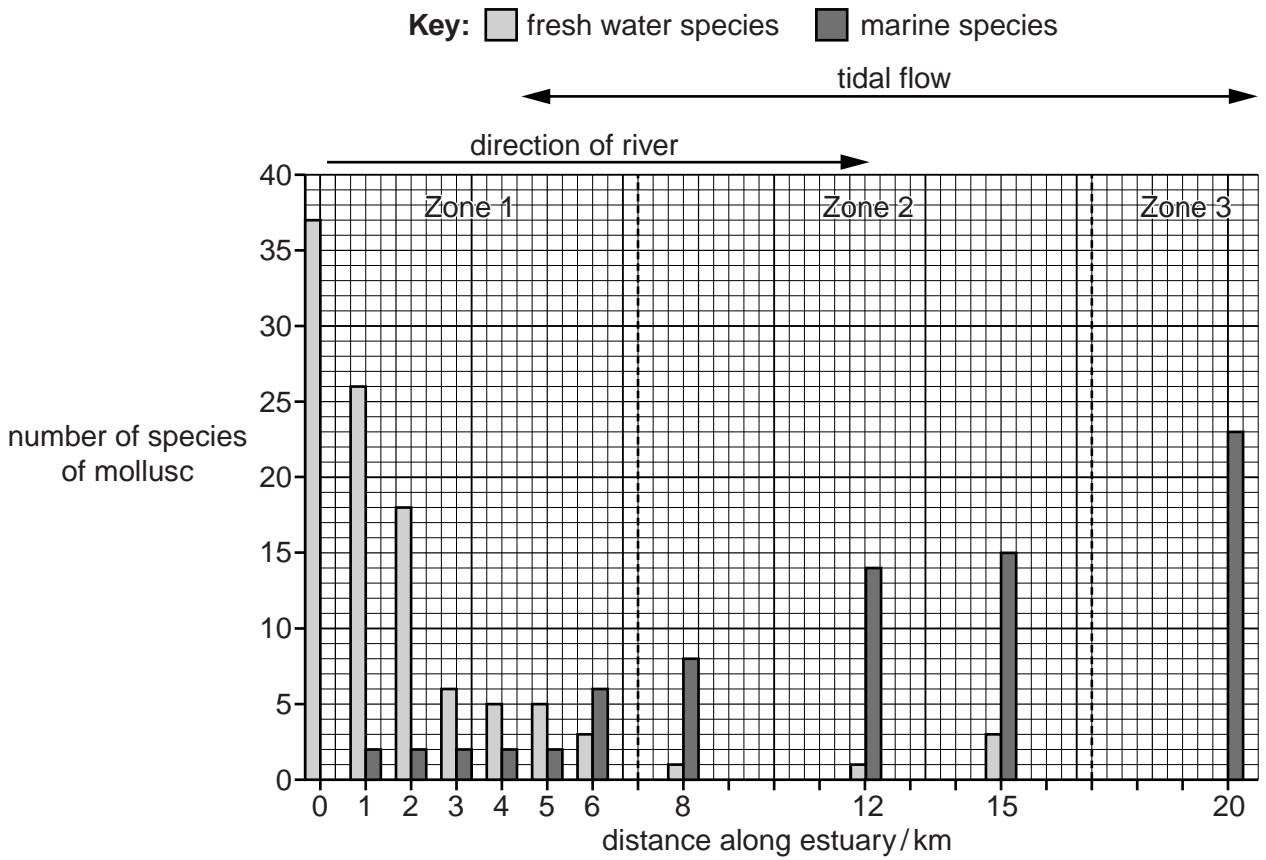

Fig. 2.1

- (i) Use the information in Fig. 2.1 to identify the distance along the estuary where 10 or fewer different species of mollusc are able to survive.

..... [1]

- (ii) Suggest why only a small number of species of mollusc can survive in this part of the estuary.

.....
 [1]

- (iii) Studies made on the species of mollusc able to survive in this part of the estuary found that there were three main groups.

Group 1. The cells of these molluscs increased in size in low salinity and decreased in size as the salinity increased.

Group 2. In low salinity these molluscs were on the surface of the sediment on the river bed but when the salinity increased they burrowed deep into the sediment.

Group 3. In low salinity these molluscs absorbed chloride ions from the water but as the salinity increased they started to excrete chloride ions.

Suggest explanations for the observed responses of each group of mollusc.

Group 1

.....

Group 2

.....

Group 3

.....

 [5]

[Total: 11]

3 (a) (i) State what is meant by the term *internal fertilisation*.

.....
 [1]

(ii) State **one** advantage and **one** disadvantage of internal fertilisation.

advantage

.....

disadvantage

..... [2]

(b) Table 3.1 shows some information about breeding in three species of shark.

Table 3.1

| species | horn shark | great white shark | hammerhead shark |
|---------------------------------|--|--|--|
| life span / years | 12 – 15 | 20 – 30 | 20 – 30 |
| number of eggs per year | 150 – 200 | 100 – 125 | 100 – 125 |
| embryo development | <ul style="list-style-type: none"> female picks up fertilised eggs and puts them in a gap between rocks embryo is fed on food stored in eggs | <ul style="list-style-type: none"> embryos develop inside female for 15 months embryos feed on unfertilised eggs | <ul style="list-style-type: none"> embryos develop inside female for 11 months embryos fed by a placenta |
| number of offspring per year | 50 – 60 | 3 – 4 | 20 – 40 |
| percentage survival to maturity | 2 – 5 | 5 | 8 – 10 |
| parental care after hatching | none | none | none |

(i) Using the information in Table 3.1, suggest why the percentage survival to maturity of the hammerhead shark is greater than in the other two species.

.....

 [2]

- (ii) Identify the species of shark that has embryo development similar to that of whales. State a reason for your answer.

species

reason

..... [2]

- (c) Table 3.2 gives some information about reproduction in whales.

Table 3.2

| species | blue whale | humpback whale | killer whale |
|------------------------------------|------------------------|------------------------|--------------------|
| life span / years | 30 – 50 | 50 – 60 | 60 – 90 |
| age at sexual maturity / years | 5 – 10 | 15 | 15 |
| gestation period / months | 10 – 12 | 11 – 12 | 15 |
| number of offspring | 1 every 2 – 3 years | 1 every 2 – 3 years | 1 every 5 years |
| maternal feeding / months | 7 – 8 | 11 | 10 – 12 |
| parental care after birth / months | 15 – 20 | 18 – 24 | 15 – 18 |
| percentage survival to maturity | 85 – 90 | 88 – 95 | 90 – 98 |

With reference to the information in Table 3.1 and Table 3.2, explain why sharks produce more offspring than whales, but a smaller percentage of the offspring survive to reach maturity.

.....

 [3]

[Total: 10]

4 Table 4.1 shows some types of fishing gear and the fish caught by each of these methods.

Table 4.1

| gear | fish caught / thousands of tonnes | | | |
|----------------------|-----------------------------------|---------|--------|-----------|
| | cod | haddock | saithe | redfish |
| benthic trawl | 87 | 46 | 66 | 55 |
| long line | 71 | 36 | 1 | 1 |
| gill nets | 23 | 1 | 4 | <1 |
| seine net | 10 | 13 | 1 | 1 |
| hand line | 6 | 1 | 3 | <1 |
| total catch | 197 | 97 | 75 | > 57 < 59 |

(a) (i) Calculate the percentage of the total catch of cod that is caught by benthic trawling. Show your working.

..... [2]

(ii) Hand line fishing is a method used by sustainable fisheries.

Calculate the total reduction in fish catch if only hand line fishing was used for cod and haddock.

..... [1]

(iii) Predict the long term effect on the cod and haddock populations if a fishery used only hand line fishing for these types of fish.

.....

.....

.....

..... [2]

(b) Fig. 4.1 shows a type of fishing net.

For
Examiner's
Use

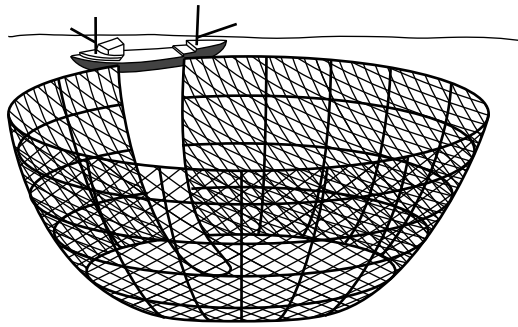

Fig. 4.1

(i) Explain why the use of sonar and global positioning satellites has increased the number of fish caught using this type of net.

.....

.....

.....

..... [2]

(ii) A large fishery uses this type of net. The management of the fishery is considering restricting the use of these nets.

Describe and explain the long term effects of unrestricted use of this type of net on the fishery.

.....

.....

.....

..... [2]

(iii) Suggest the short-term and long-term sociological impact if the use of these nets is restricted.

short-term impact

.....

.....

long-term impact

.....

.....

..... [3]

[Total: 12]

5 (a) Fig. 5.1 shows the monthly production of groupers in one part of S.E. Asia.

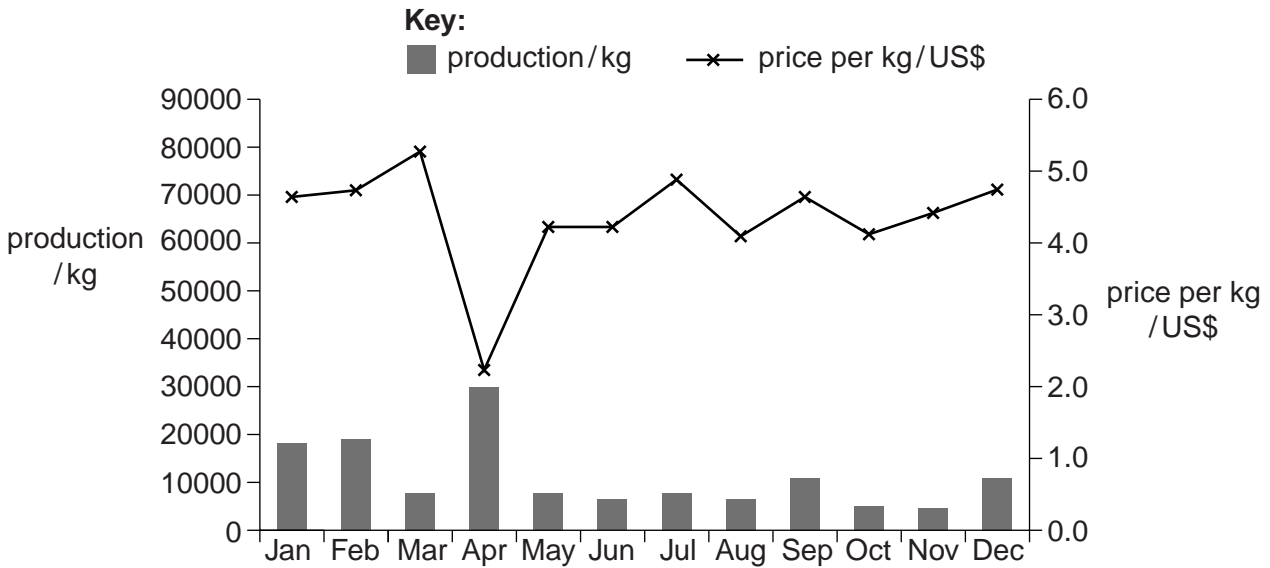

Fig. 5.1

(i) State the two months of the year when production was lowest.

..... [1]

(ii) Suggest why the total value of the grouper production rose in April although the price per kg fell.

.....

 [2]

(b) Fig. 5.2 shows the aquaculture system used for these groupers.

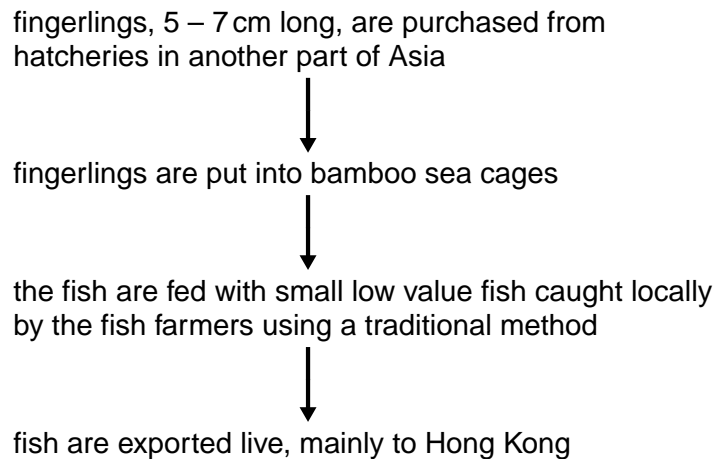

Fig. 5.2

(i) Identify the type of aquaculture system used to rear these groupers.

.....

Give **two** reasons for your answer.

1.

.....

2.

..... [3]

(ii) Suggest why the use of fingerlings from a hatchery will help to maintain the wild populations of grouper.

.....

..... [1]

(c) Groupers are transported while they are still alive. The fish are prepared for transport using the following procedure.

- Groupers weighing about 400 g are collected and placed in a tank which is aerated for 1–2 hours.
- The temperature is lowered to 18 °C.
- Three or four fish are placed in a plastic bag with enough water to cover the fish.
- These bags are packed in ice.

Suggest reasons for the treatment of the fish to prepare them for transport.

.....

.....

.....

.....

.....

..... [3]

(d) In the future, groupers grown using aquaculture may be genetically engineered with a growth promoting gene.

Suggest **two** benefits of genetically modifying these groupers.

1.

.....

2.

..... [2]

[Total: 12]

6 (a) (i) Explain what is meant by the term *dredging*.

.....
.....
..... [2]

(ii) State **two** reasons why dredging might be carried out.

1.
.....
2.
..... [2]

(b) Describe **two** different ecological effects that might be caused by dredging.

ecological effect 1
.....
.....
.....
.....
ecological effect 2
.....
.....
.....
..... [4]

[Total: 8]

BLANK PAGE

Turn over for Question 7

7 (a) Ecotourism is a fast growing area that many countries are trying to develop. Some of the aims of ecotourism are

1. to encourage responsible practice in tourism
2. to have little effect on the environment
3. to educate the traveller
4. to create political power for local communities
5. to help understanding of different cultures

Explain what is meant by 'responsible practice in tourism'.

.....

.....

.....

.....

.....

.....

..... [3]

(b) Read the following descriptions about tourist destinations that have been developed in different parts of the world. In each case the destination has been developed in an area that had been overexploited and claims to be suitable for ecotourists.

For each of these tourist destinations, discuss how it meets the aims of ecotourism.

(i)

Destination 1

A beach resort that has white sandy beaches and joins onto a National Park.

The 75 cabin style rooms are scattered in the surrounding local vegetation.

Each room has an en-suite bathroom. All of the water is recycled.

Activities include surfing, scuba diving and glass bottom boat trips.

The National Park has clearly marked trails and a visitor centre where conducted tours with local guides can be organised. There is a bird sanctuary within the National Park.

.....

.....

.....

.....

.....

.....

.....

(ii)

Destination 2

A marine reserve which provides a spawning ground for snapper fish and a site where whale sharks gather every year.

Commercial fishing is on a sustainable basis.

There are two hotels, one budget and one luxury standard.

Kayak sailing and deep sea diving and snorkelling are available.

.....
.....
.....
.....
.....
.....

(iii)

Destination 3

A tropical island popular with divers due to the extensive coral reefs. There are many dive sites with high biodiversity, all within a 40 minute boat ride of the island.

Accommodation on the island includes a range of luxury and medium priced hotels, self-catering apartments and camping sites.

Visitors can join a local conservation project that is organised by a British diver. This conservation project carries out surveys and collects data about the coral reefs.

The project is also involved in activities with local people, including building and maintaining a coral nursery, beach cleaning and an educational programme in local schools.

.....
.....
.....
.....
.....
.....

[9]

[Total: 12]

BLANK PAGE

Copyright Acknowledgements:

- Question 2(b) Fig. 2.1 © J Levinton; *Marine Biology, Function, Biodiversity, Ecology, 2nd Edition*; Oxford University Press; 2001.
Question 4 Fig. 4.1 © <http://old.fisheries.is/ships/gear.htm>.
Question 4 Fig. 4.1 Image © <http://opinion.inquirer.net/inquireropinion/talkofthetown/view/20100403-262215/Banontunafishinginthe%20PacificBoonorBan>.
Question 5(a) Fig. 5.1 Graph © *Mariculture Development Opportunities in SE Sulawesi, Indonesia*;
<http://www.thefishsite.com/articles/600/mariculture-development-opportunities-in-se-sulawesi-indonesia>.

Permission to reproduce items where third-party owned material protected by copyright is included has been sought and cleared where possible. Every reasonable effort has been made by the publisher (UCLES) to trace copyright holders, but if any items requiring clearance have unwittingly been included, the publisher will be pleased to make amends at the earliest possible opportunity.

University of Cambridge International Examinations is part of the Cambridge Assessment Group. Cambridge Assessment is the brand name of University of Cambridge Local Examinations Syndicate (UCLES), which is itself a department of the University of Cambridge.